

5800 115V Refrigeration Module

Removal and Replacement

These instructions cover the 4700 and 5800 115V refrigerator module replacement. Before attempting to remove and replace a module observe the following precautions:

WARNING

Removing a module exposes you to electrical and mechanical hazards. Always disconnect the AC power cord before attempting to remove any module. Only trained service personnel may remove or replace these modules.

CAUTION

Modules contain circuit boards and sensitive electronics that can be damaged by a discharge of static electricity. Avoid touching the internal components. Only handle the module by the edges or exterior surfaces.

CAUTION

Electrical connectors and wires can be damaged if improperly handled. Electrical connectors must only be handled by the connector body. Never grasp the wires or use tools to disconnect a connector. Never allow a module to hang by its wiring.

CAUTION



Earth ground bonding conductor. Do not remove or disconnect. If this conductor must be disconnected to remove a module, it must be reconnected when installing the replacement module.

Required Parts and Tools

- Replacement refrigeration module assembly:
 - 115 VAC sampler (P/N 60-5804-190)
 - Nylon cable tie (P/N 489-0110-00)
 - Permagum¹ sealant (P/N 090-0200-38)
- #3 Phillips screwdriver
- 1¹/₃₂" nut driver or socket wrench
- Wire cutters
- Flat-blade screwdriver
- Putty knife

1. Permagum is a registered trademark of the Presstite Engineering Company.

Removing the Module - Serial Number 216B and Newer

Complete the following to remove the existing refrigerator module.

1. Unplug the line cord to remove the AC power.
2. Remove the coil shield, back cover, and insulation panel (Figure 1). When removing the foam insulation panel, take precautions not to damage the foam around the tubing (see inset, Figure 1).

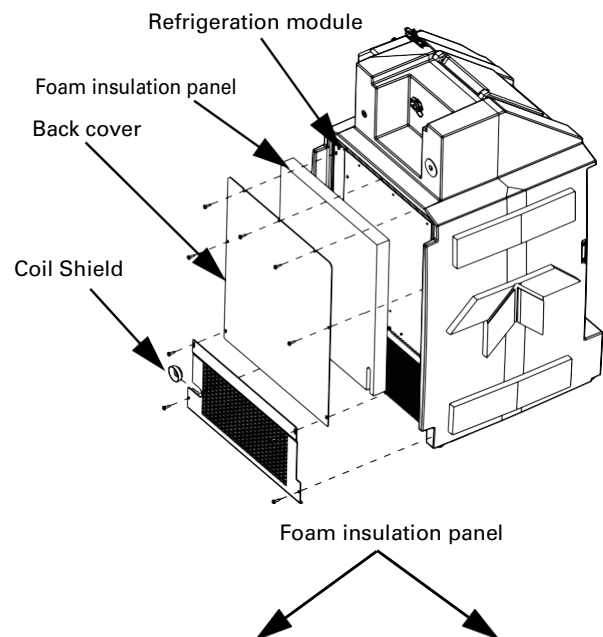

Figure 1: Open rear compartment

3. Cut the cable tie holding the power cord that runs through the refrigeration assembly (Figure 2).

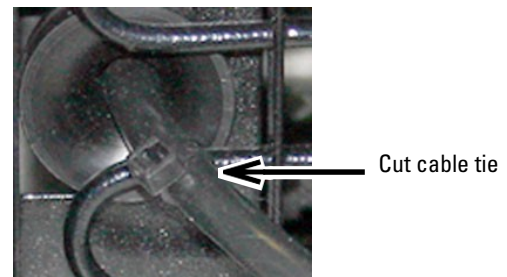

Figure 2: Cut cable tie to free line cord

4. Remove the refrigeration module mounting screws (Figure 3).
5. Carefully pull the module out and rotate clockwise to expose the wiring connectors. The bushing holding the AC line cord in place should slide along the cord (see inset, Figure 3). During reinstallation, the slack created in this step must be removed.

CAUTION

Keep the module as close to the refrigerator body as possible to avoid pulling the wiring taut and damaging the connectors.

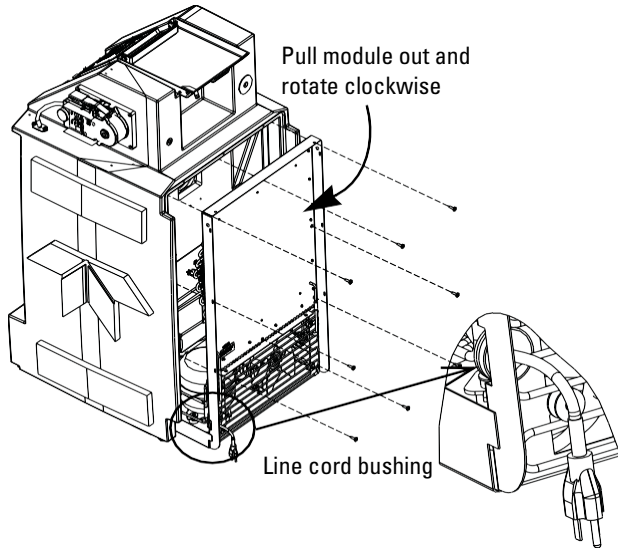

Figure 3: Remove refrigeration module mounting screws

6. Remove the terminal cover of the compressor (Figure 4). For serial number 219K02629 or newer, remove the screw and lock washer that hold the green/yellow ground wire in place on the compressor.



Figure 4: Access compressor overload A screwdriver may be used to release the latch.

7. Disconnect the four (4) compressor wires from the power supply cable (Figure 5).
 - a. While holding the overload relay in place, disconnect the brown wire.
 - b. Disconnect the blue wire from the capacitor and relay assembly from the gray wire on the power supply cable.
 - c. Disconnect the black heater wire from the black wire on the power supply cable.
 - d. With the $\frac{11}{32}$ " nut driver or socket wrench, remove the nut holding the green/yellow ground wire on the module chassis.

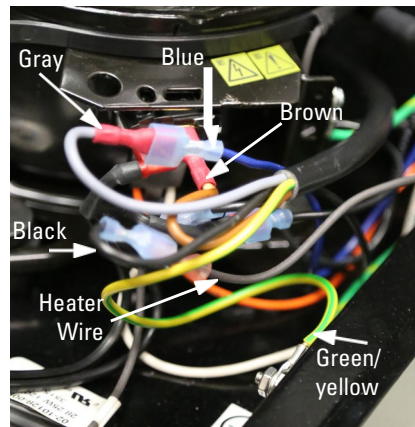

Figure 5: Disconnect compressor wires

8. The evaporator temperature sensor is mounted on the sixth coil up on the evaporator (Figure 6) and has a black rubber molded housing. Cut the ties holding this sensor in place and move it out of the frame.

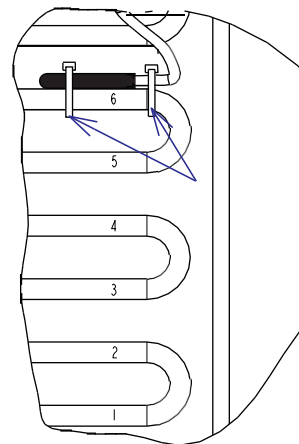

Figure 6: Remove evaporator temperature sensor

9. Remove the power cord from the refrigeration assembly.
 - a. Slide the bushing sideways away from the refrigeration module until it is free (Figure 7). Avoid bending the refrigeration tubing.
 - b. Pull the power cord through the module.

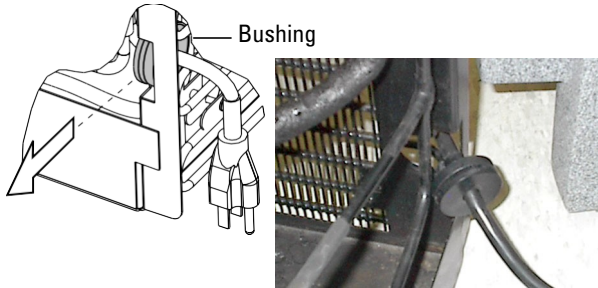

Figure 7: Remove line cord from module

Module Replacement

Complete the following to install the new refrigerator module.

10. Ensure that the control wiring runs through the channel in the refrigerator body (Figure 8).

Note

Two thick, black cables connect the power supply with the AC and compressor (Figure 8). **Ensure that cables are side by side and not crossed during reassembly.**

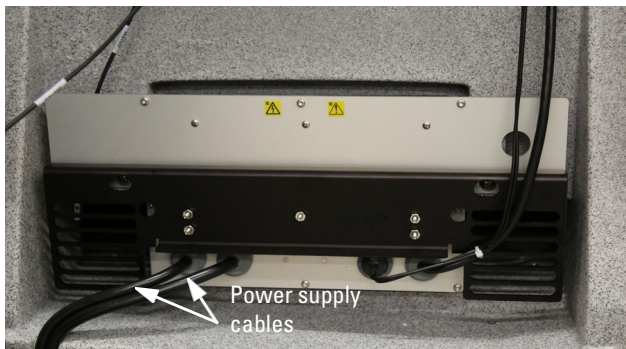
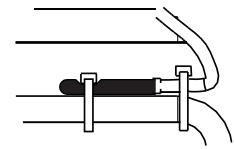

Figure 8: Rear view with module removed

11. Install the evaporator temperature sensor at the top of the sixth coil (Figure 6), using the cable ties provided. To operate correctly, the sensor must be mounted in the exact position illustrated in Figure 6.

Note

When installing the black molded sensor do not overtighten the cable tie on the sensor body, as internal damage may occur. The sensor should be snug against the coil, but the rubber housing should not be visibly dented.



12. Reconnect the four (4) compressor wires to the power supply cable (Figure 5):
 - a. Connect the brown wire to the overload relay.
 - b. Connect the gray wire from the power supply to the blue wire from the capacitor and relay assembly.
 - c. Connect the black wire from the power supply to a black wire from the heater.
 - d. With the $1\frac{1}{32}$ " wrench, connect the green/yellow ground wire with the nut to the threaded standoff on the frame.
13. Reinstall the terminal cover onto the compressor.
14. Connect the green/yellow ground wire from the module chassis to the compressor with the included screw and lock washer.



CAUTION



Earth ground bonding conductor. Ensure that the green/yellow wire is reconnected to this terminal.

15. Slide the refrigeration module to the rear of the refrigerator and place the drain tube in the drip pan on the module (Figure 9).



Figure 9: Position drain tube in front half of the drip pan

16. Ensure the black gasket is aligned and gasket nubs are inserted in corresponding holes on the frame of the refrigerator module (Figure 10).

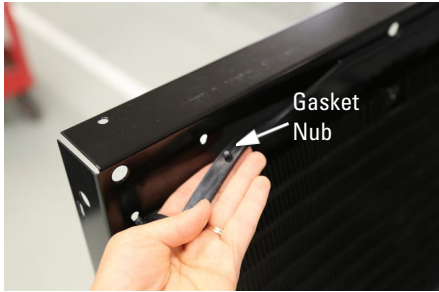

Figure 10: Position gasket on refrigeration module frame and ensure each gasket nub is inserted in corresponding hole

17. Route the AC power cord through the refrigeration module and secure it in place with the bushing (Figure 11).

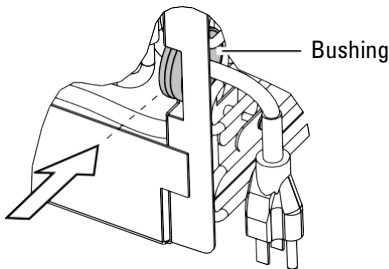

Figure 11: Secure AC Power Cord (Full length of line cord not depicted)

CAUTION

When reinstalling the refrigeration module, do not pinch the sensor wiring.

18. Install the module, tipping the top back while sliding the bottom forward. When the bottom of the system is in place, push the top into place (Figure 12). Ensure the slack in the power cord is removed before securing refrigeration module frame.

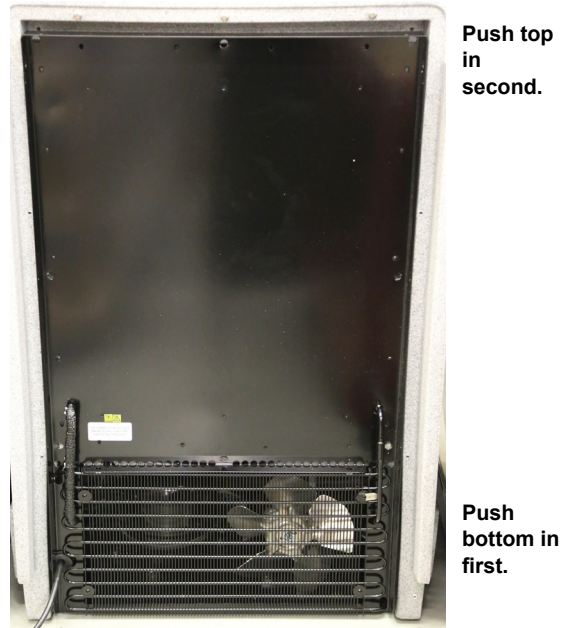

Figure 12: Slide module into place

CAUTION

When reinstalling all self-tapping screws, avoid destroying the plastic threads. First seat each screw in its hole and, without pressing down, rotate the screw counter-clockwise until it falls into its thread groove with a "click." Then tighten the screw.

- 19. Reinstall the refrigeration module mounting screws (Step 4).
- 20. Install the cable tie to secure the power cord that runs through the refrigeration assembly (Figure 13).

CAUTION

During reinstallation, Ensure the slack in the power cord is removed before securing refrigeration module frame.

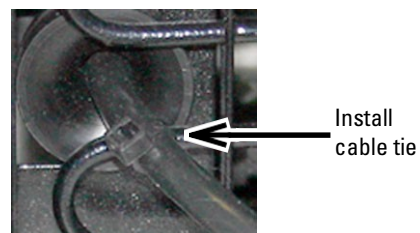

Figure 13: Install cable tie to secure power cord

21. Reinstall the coil shield, back cover, and insulation panel (Figure 1). When installing the foam insulation panel, take precautions not to damage the foam around the tubing (see inset, Figure 1).
22. Restore AC power to the 5800 refrigerator.
23. Review the refrigerator temperature diagnostic test, as described in the following section.

Refrigerator Temperature Diagnostic

The REFRIG TEMPERATURE diagnostic test displays the temperature of the refrigerated compartment.

To start the diagnostics from the standby screen:

1. Select the CONFIGURE option and press Enter.

```
PROGRAM  CONFIGURE
VIEW     LOG
```

2. Press the left arrow button until the RUN DIAGNOSTICS option is displayed. Press Enter.

```
SELECT OPTION: (<-->)
RUN DIAGNOSTICS
```

```
SELECT DIAG: (<-->)
TEST 'RAM'
```

3. Press the right arrow key 7 times to display REFRIG TEMPERATURE. Press Enter to start the test.

```
SELECT DIAG: (<-->)
REFRIG TEMPERATURE
```

When this test is started, the sampler will display the temperature until the Stop or Enter button is pressed. There is no pass or fail. This test provides continuous temperature monitoring.

```
REFRIG TEMPERATURE:
AIR=_C  EVAP=_C
```

As the refrigerator cycles off and on, the reported temperature will rise above and below the set temperature. However, the average reported temperature should be the same as the configured temperature. The evaporator temperature may read as low as -20°C at times; this is considered normal.

If the screen displays an asterisk (*) or inaccurate temperature reading, the temperature sensor cable may be malfunctioning.

Removing the Module - Serial Number 216B and Older

Complete the following to remove the existing refrigerator module.

1. Unplug the line cord to remove the AC power.
2. Remove the cover brace, back cover, and insulation panel (Figure 14).

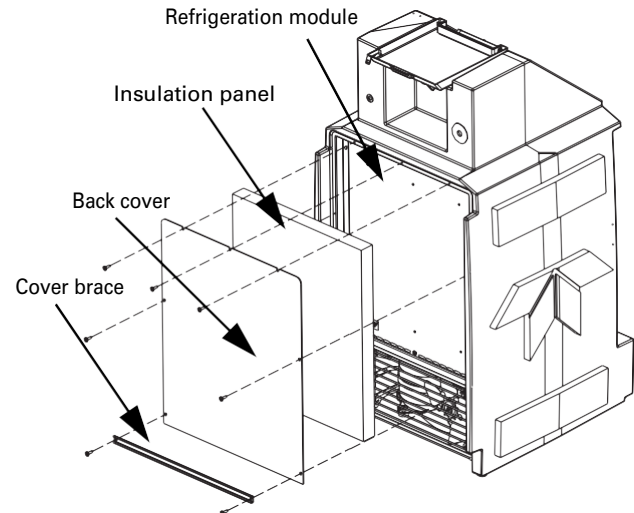

Figure 14: Open rear compartment

3. Cut the cable tie holding the power cord that runs through the refrigeration assembly (Figure 15).



Figure 15: Cut cable tie to free line cord

4. Remove the refrigeration module mounting screws (Figure 16).

Note

Note that the refrigeration module has an adhesive strip just above the rear coils. The bottom center screw may be slightly hidden by this.

5. Carefully pull the module out and rotate clockwise to expose the wiring connectors. The bushing holding the AC line cord in place should slide along the cord (see Figure 16, inset). During reinstallation, the slack created in this step must be removed.

CAUTION

Keep the module as close to the refrigerator body as possible to avoid pulling the wiring taut and damaging the connectors.

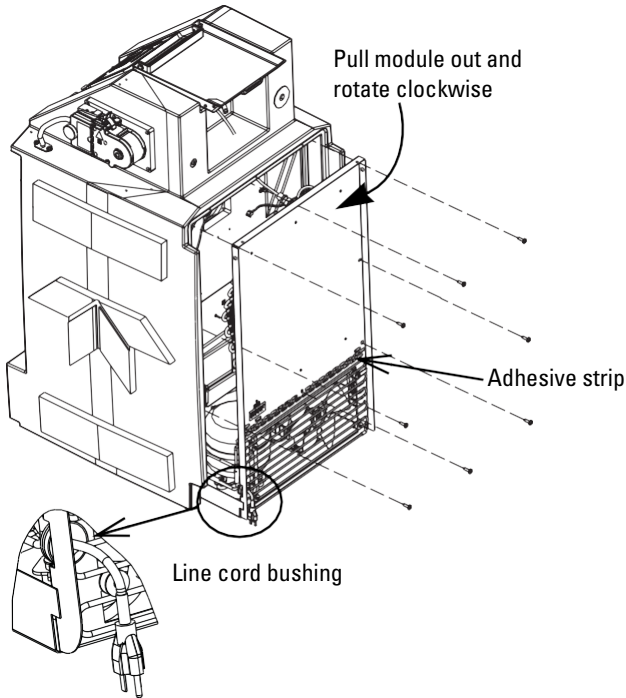

Figure 16: Remove refrigeration module

6. Remove the terminal cover of the compressor (Figure 17).

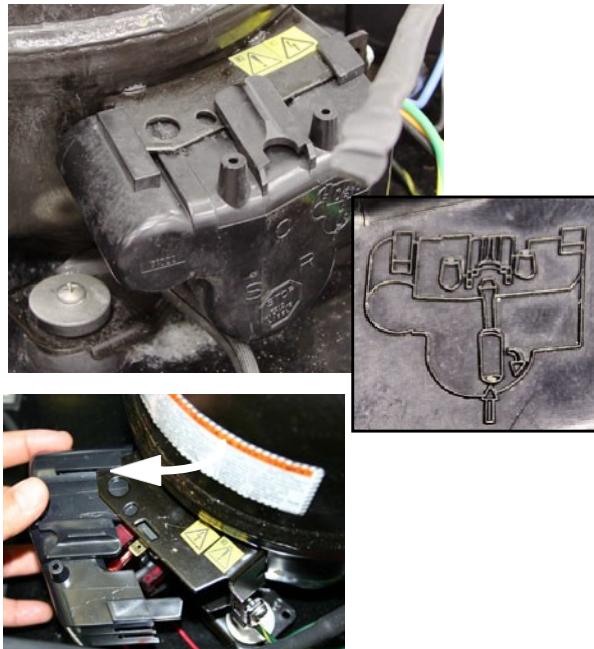

Figure 17: Access compressor overload and relay

A screwdriver may be used to release the latch.

7. Disconnect the three (3) compressor wires from the power supply cable (Figure 18).
 - a. While holding the overload relay in place, disconnect the brown wire.

Note

If the unit has a newer power supply with four wires (brown, gray, black and green) refer to Step 7 in section 216B on newer wiring instructions.

- b. Disconnect the blue wire from the blue wire on the power supply cable or the blue wire from the capacitor and relay.
 - c. With the $\frac{11}{32}$ " nut driver or socket wrench, remove the nut holding the green/yellow ground wire on the module chassis.

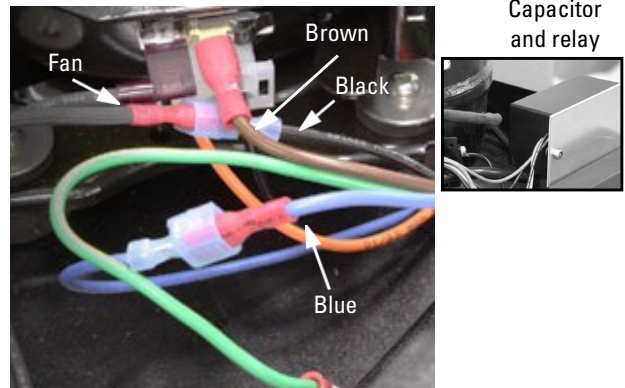

Figure 18: Disconnect compressor wires

8. The evaporator temperature sensor is mounted on the sixth coil up on the evaporator (Figure 19). Note that some older 4700 models have a metal sensor, while current models have a black rubber molded housing. Cut the ties holding the evaporator sensor in place and move it out of the frame.

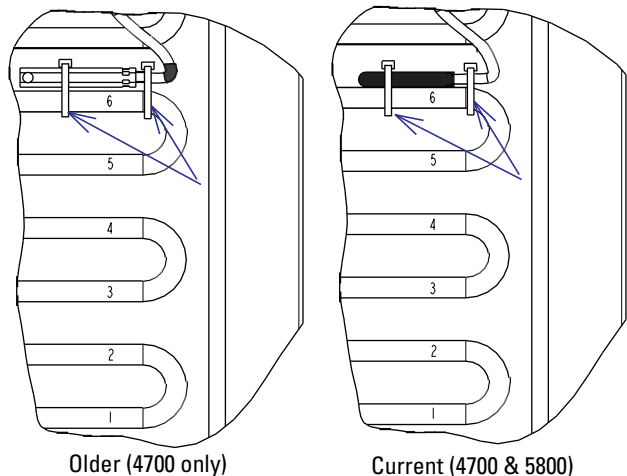

Figure 19: Remove evaporator temperature sensor

9. Remove the power cord from the refrigeration assembly.
 - a. Slide the bushing sideways away from the refrigeration module until it is free. (Figure 20). Avoid bending the refrigeration tubing.
 - b. Pull the power cord through the refrigeration module.

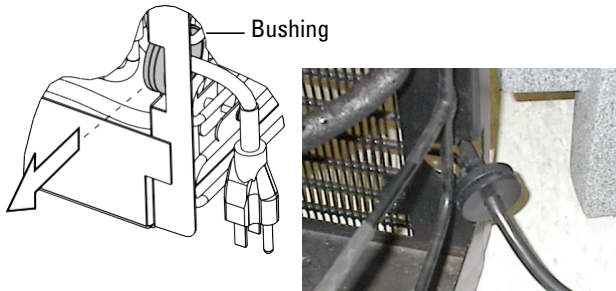

Figure 20: Remove line cord from module

Module Replacement

Complete the following to install the new refrigeration module.

10. Ensure that the power supply cables are routed through the proper channels in the refrigerator housing (Figure 21).

Note

Two thick, black cables connect the power supply with the AC and compressor. **Ensure that cables are side by side and not crossed during reassembly.**

11. Using a flat screwdriver or putty knife, remove the adhesive strips from the refrigerator housing (Figure 21).

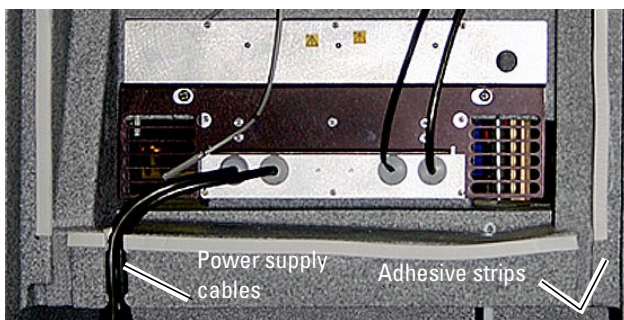

Figure 21: Rear view with module removed Route power supply cables then remove adhesive strips

12. Seal the indicated areas with Permagum¹ sealing compound (Figure 22).

1. Permagum is a registered trademark of the Presstite Engineering Company.

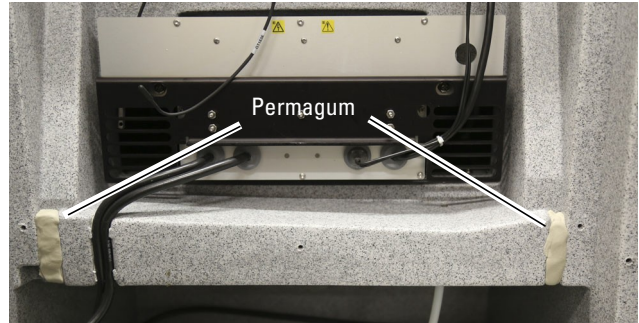

Figure 22: Seal grooves on refrigerator housing with Permagum

13. Route the AC power cord through the refrigeration module and secure it in place with the bushing (Figure 23).

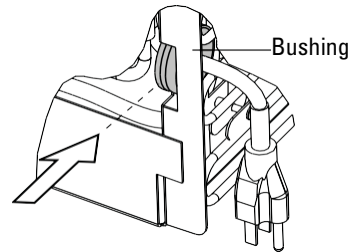

Figure 23: Secure AC Power Cord (Full length of line cord not depicted)

14. Install the evaporator temperature sensor at the top of the sixth coil (Figure 19), using the cable ties provided.

To operate correctly the sensor must be mounted in the exact position illustrated in Figure 19.

Note

When installing the black molded sensor, do not overtighten the cable tie on the sensor body, as internal damage may occur. The sensor should be snug against the coil, but the rubber housing should not be visibly dented.

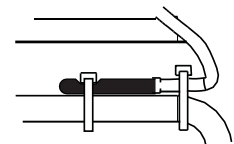

15. Connect the compressor power wires (refer to Figure 18):

Note

If unit has newer power supply with four wires (brown, gray, black and green) refer to step 12 above in the 216B and newer wiring instructions.

- a. Connect the brown wire to the overload.
- b. Connect the blue wire to the blue wire from the new capacitor and relay.

- c. With the $11/32$ " wrench, connect the green and yellow ground wire with the nut to the threaded standoff on the frame.

Note

The black wire from the heater is not utilized.

- 16. Reinstall the terminal cover that was removed in step 6.
- 17. Connect the green/yellow ground wire from the module chassis to the compressor with the included screw and lock washer.

 **CAUTION**

Earth ground bonding conductor. Ensure the green/yellow wire is reconnected to this terminal.



- 18. Slide the refrigeration module to the rear of the refrigerator and place the drain tube in the drip pan on the module (Figure 24).

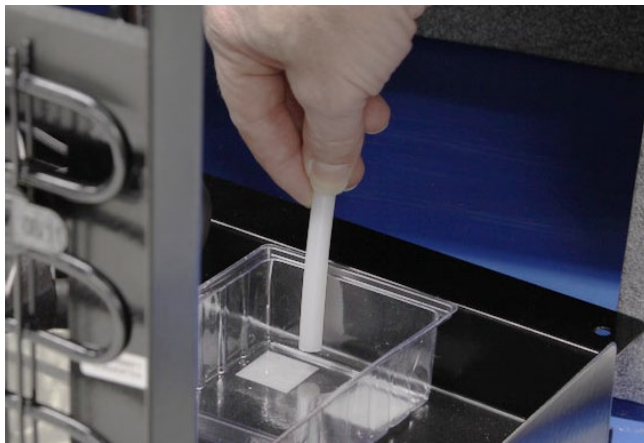

Figure 24: Position drain tube in front half of drip pan.

- 19. Ensure the black gasket is aligned and gasket nubs are inserted in corresponding holes on the frame of the refrigeration module (Figure 25).

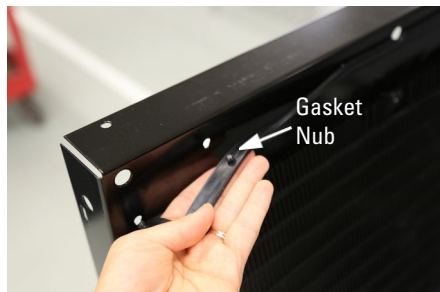

Figure 25: Position gasket on refrigeration module frame and ensure each gasket nub is inserted in corresponding hole

- 20. Route the AC power cord through the refrigeration module and secure it in place with the bushing (Figure 26).

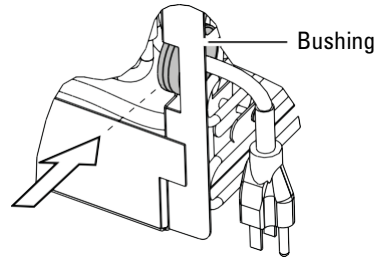

Figure 26: Secure AC Power Cord (Full length of line cord not depicted)

 **CAUTION**

When reinstalling the refrigeration module, do not pinch the sensor wiring.

- 21. Install the module, tipping the top back while sliding the bottom forward. When the bottom of the system is in place, push the top into place (Figure 27). Ensure the slack in the power cord is removed before securing refrigeration module frame.

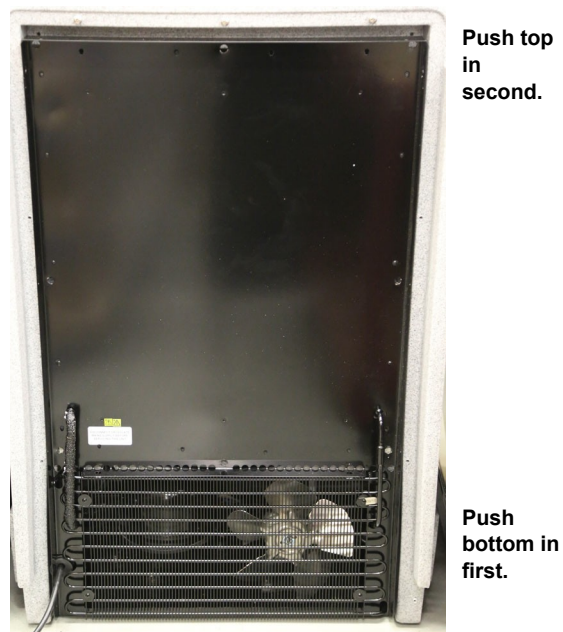

Figure 27: Slide module into place

 **CAUTION**

When reinstalling all self-tapping screws, avoid destroying the plastic threads. First seat each screw in its hole and, without pressing down, rotate the screw counter-clockwise until it falls into its thread groove with a "click." Then tighten the screw.

- 22. Reinstall the refrigeration module mounting screws (Step 4).

23. Install the cable tie to secure the power cord that runs through the refrigeration assembly (Figure 28). Ensure the slack in the power cord is removed before securing refrigeration module frame.

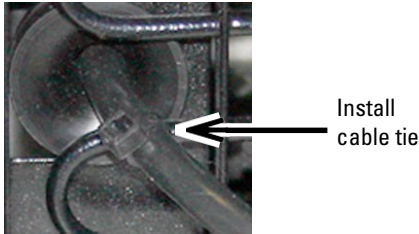

Figure 28: Install cable tie to secure power cord

- a. Mark two corners of the foam insulation with 1 1/2" x 4 1/2" lines (Figure 29).

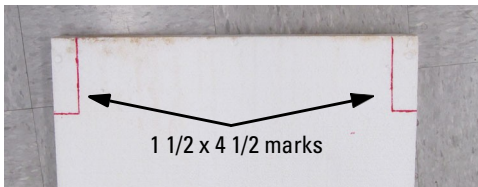

Figure 29: Mark foam insulation

- b. Cut the insulation panel as marked in the previous step (Figure 30).



Figure 30: Cut foam insulation

- c. Install foam panel on the refrigeration module, taking precautions not to damage the foam around the tubing (Figure 31).

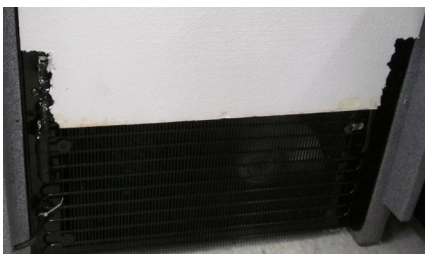

Figure 31: Install the insulation panel

24. Reinstall the cover brace, back cover, and insulation panel (Figure 14).
 - a. Restore AC power to the 5800 refrigerator.
25. Review the refrigerator temperature diagnostic test, as described in the following section.

Refrigerator Temperature Diagnostic

The REFRIG TEMPERATURE diagnostic displays the temperature of the refrigerated compartment.

To start the diagnostics from the standby screen:

1. Select the CONFIGURE option and press Enter.

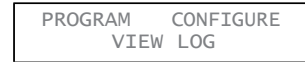

2. Press the left arrow button until the RUN DIAGNOSTICS option is displayed. Press Enter.



3. Press the right arrow key 7 times to display REFRIG TEMPERATURE. Press Enter to start the test.



When this test is started, the sampler should display the temperature until you press the Stop or Enter button. There is no pass or fail. This test simply provides continuous temperature monitoring.



As the refrigerator cycles off and on, the reported temperature will rise above and below the set temperature. However, the average reported temperature should be the same as the configured temperature. The evaporator temperature may at times read as low as -20° C; this is considered normal.

If the screen displays an asterisk (*) or inaccurate temperature reading, the temperature sensor cable may be malfunctioning.

Last modified November 8, 2019

Teledyne Isco

P.O. Box 82531, Lincoln, Nebraska, 68501 USA
 Toll-free: (866) 298-6174 • Phone: (402) 464-0231 • Fax: (402) 465-3001
 E-mail: IscoService@teledyne.com

Teledyne Isco is continually improving its products and reserves the right to change product specifications, replacement parts, schematics, and instructions without notice.

